

# Installation & User's Guide (Instructions & Limitations)

## Landing Height System

(NORSEE Certified Edition)

### Models:

**LS-200-B / LHS-200-C**

Date: 05/23/2024

Rev A3

### Revision History

Revision	Date	Description
A	07/14/2022	First Release
A1	09/15/2022	Clarification for GPS Input usage & added features
A2	10/01/2022	Added Female voice and other Audio options.
A3	05/23/2024	Removed 5ft limitation for Certified Airplanes.

© 2022 Microkit Solutions LLC. All rights reserved.

This document may not be reproduced, copied or modified for any purpose without the express written permission of Microkit Solutions LLC. Printed, downloaded, or transmitted copies for any purpose are considered for reference only. Unauthorized use or distribution of this document is prohibited. This document can only be used as a reference to aid in the installation of the indicated system.

## **1 Limited Warranty / Disclaimers**

Microkit Solutions LLC warrants this product for materials and workmanship for a period of one year starting from the date of installation. Microkit Solutions, at its sole discretion, will either repair or replace this product if found to be defective due to material or workmanship during this period and under normal use.

This limited warranty does not cover units which have been opened, disassembled, altered, modified, or tampered with in any form. This warranty does not apply to cosmetic damage, damage caused by accident, misuse, abuse, fire or flood, theft, improper connections, or installation errors.

All repair and/or replacement under this warranty are free to the customer. However, the customer is responsible for any shipping charges and any related removal and reinstallation costs.

This warranty covers the original purchaser only. This limited warranty is not transferable to subsequent purchasers or owners of this product.

MICROKIT SOLUTIONS LLC, ITS STAFF, DEALERS, RESELLERS AND THEIR STAFF IN NO EVENT SHALL BE LIABLE FOR ANY WARRANTIES, REMEDIES, DAMAGES, DIRECT, INCIDENTAL, CONSEQUENTIAL, OR INDIRECT RESULTING FROM THE USE OR INABILITY TO USE AND/OR MISUSE OF THIS PRODUCT

THIS LIMITED WARRANTY AND CONDITIONS ARE EXCLUSIVE AND IN LIEU OF ALL OTHER WARRANTIES, REMEDIES AND CONDITIONS, WHETHER ORAL OR WRITTEN, EXPRESS, OR IMPLIED.

SOME STATES DO NOT ALLOW THE EXCLUSION OF INCIDENTAL OR CONSEQUENTIAL DAMAGES, SO PART OF THE ABOVE LIMITATIONS MAY NOT APPLY TO YOU.

# Table of Contents

<b>1</b>	<b>Limited Warranty / Disclaimers</b>	<b>2</b>
<b>2</b>	<b>Introduction</b>	<b>5</b>
<b>3</b>	<b>Specifications</b>	<b>6</b>
<b>4</b>	<b>Installation Instructions &amp; Limitations</b>	<b>6</b>
4.1	Installers	7
4.2	Location	7
4.3	Connection Limitation	9
4.4	Pre-installation verification	10
4.5	Installation of Landing Height System Unit	11
4.5.1	Internal attachment to Access Panel/Inspection Plate	11
4.5.2	Wiring	15
4.5.3	Audio Interface	18
4.5.4	Software Setup	18
<b>5</b>	<b>Maintenance</b>	<b>19</b>
<b>6</b>	<b>Operating Limitations</b>	<b>19</b>
<b>7</b>	<b>Wi-Fi Connection</b>	<b>20</b>
<b>8</b>	<b>Wi-Fi Menu</b>	<b>21</b>
8.1	Main Page	21
8.2	Installed Height Page	22
8.3	Audio Page	23
8.4	Wi-Fi Page	24
8.5	System Page	24
8.6	GPS Setup	24
8.7	Audio Options	27

## 2 Introduction

The Landing Height System provides height above landing surface audio announcements when reaching a specific height above the ground.

It uses a built-in LIDAR with eye-safe Class 1 Laser module for ground range. For the purpose of this document; LIDAR module or Laser module are used interchangeably. A hard surface such as Tarmac, Asphalt, and Concrete runways, along with turf/grass or dirt strip are suitable for accurate range reading.

This guide covers two LHS models; **LHS-200-B and LHS-200-C**. These units are not approved for external installations (under a wing access panel). **These two models are designed and approved for internal installations only (above an access panel).**

The LHS unit is designed to start announcement after it detects a descending profile and a valid surface range acquired. ***Note that the LHS may skip the first announcement depending on the approach angle, descent rate, ambient light, sun exposure and other terrain environments before reaching the actual runway surface.***

The Landing Height System announces the height during the Landing phase. It is specifically designed not to announce on Takeoff, though it does announce the range during a go-around maneuver if the go-around is initiated below 50 feet.

This product is not suitable and not approved for use over water or if the runway has a water level of 3" or more.

This system accepts standard aircraft power from 12V or 24V systems. It outputs a Single-Ended (< 1W) Audio signal capable of loading a standard 8 Ohm speakers or Audio Input HI pin within the Audio Panel or Intercom.

**The Landing Height system is not a required system and may not be used as a substitution for any certificated aircraft system.”**

### 3 Specifications

Voltage Supply: 9V-28V (30V MAX)

Power consumption: 1W Nominal; Peak 150mA @ 12V

Operating Temperature: -4° F (-20° C) to +140° F (60° C)

Storage Temperature: -4° F (-20° C) to 185° F (85° C)

Weight: 210 gm (7.5 oz)

Dimensions: 93 mm (3.66”) (L) x 53 (2.10”) mm (W) x 60 mm (2.36”) (H)

### 4 Installation Instructions & Limitations

**Installers are required to read this section fully before starting the installation and to note any limitations for the installation of this Landing Height System.**

For installation on a Pressurized Airplane; penetration of the pressurized vessel to allow for routing wires may be considered a major alteration and may require further FAA approval if the approved existing penetration wire connectors are not used.

Installation of the Landing Height system is supplemental only; it is not intended as a replacement for or modification to an existing, approved, or required system. No operational credit may be taken for installation of this system.

## 4.1 Installers

This unit must be installed by an authorized mechanic for the Aircraft type/ model. Installers are required to log the installation appropriately. Installers are also required to verify the pilot is able to switch off the LHS unit or Audio output on-demand using an appropriate method mentioned below.

The latest LHS FAA NORSEE approval for operation on certified airplanes no longer limits the height announcements to stop at 5 ft. Owners/Operators for Certified Airplanes are now allowed to enable the unit to announce below 5 ft.

## 4.2 Location

The two LHS models covered in this guide are approved to be installed on an “Access Panel/Inspection plate internally.

The installation may be accomplished with a log book sign off if it is minor, but will require additional FAA approval if it is determined to be major. Note: Installers should contact the appropriate FAA office for evaluation if not installing the LHS on an inspection plate or access panel. Installation using an Inspection plate or access panel is considered minor. Penetration of pressurized vessels may be considered major and further FAA approval may be required depending on the penetration method.

Do not install the unit in the engine exhaust soot stream.

Installers must verify the installation will not interfere with existing control rods, cables or other moving parts.

Any adjacent cables, control rods or moving parts must be checked for its full movement range, so the planned wiring and unit location does not interfere with any moving parts or surfaces. The unit needs an unobstructed view of the ground below. It can be installed at an angle, the angle will be detected during first setup and adjusted internally, so the system can provide the correct vertical range.

At the base of the unit, the spread of the laser beam is small, about 0.5 degree. The spread increases at this rate as distance increases. Any hard surfaces or objects (such as landing gear or fairings) should not be seen by the beam depending on the installed height above ground level.

Generally, the beam diameter would not be more than 1” using the highest possible installation point. It is best to choose a location a few inches away from the wheels and this can be easily verified before any actual wiring or permanent installation fixture.

The installer must verify the Pilot is able to switch off the LHS if desired using one of the following:

- A dedicated LHS audio panel “Switched” channel to disable the audio annunciation
- A dedicated LHS push-pull circuit breaker to remove power
- Panel mounted LHS toggle-switch to remove power

***Refer to Section 4.3 for more details.***

### 4.3 Connection Limitation

A dedicated 1A circuit breaker with Push/Pull feature is the recommended method for aircraft power connection to the LHS unit. This circuit breaker must be labeled “LHS”.

If a Push/Pull type dedicated circuit breaker is not suitable for installation; a standard aircraft circuit breaker can be used but another method to allow the pilot to disable Audio or the system itself must be used. One method is to install a toggle switch labeled “LHS” which allows the pilot to switch off the unit on-demand.

A “Switched” type Audio input on the Audio Panel can also serve as a means to allow the pilot to disable the Audio announcements.

If the circuit breaker is the only means to disable the unit; this circuit breaker must be dedicated 1A breaker and of the Push/Pull type labeled with “LHS”

This requirement ensures the pilot is able to physically switch off or disable the Audio input channel in the event the system did develop an unforeseen error situation where the pilot determined that the system is malfunctioning. For example, hearing 10 feet while on downwind.

If a “Switched” type audio channel can be used to disable the Audio or a toggle switch is installed; the unit can share its power with non-essential accessories such as cigarette lighter.

## 4.4 Pre-installation verification

Audio functionality must be checked prior to fixture installation or drilling/wiring. This ensures compatibility and allows the correct selection of the Audio input channel prior to actual installation.

With the unit in hand, prepare a temporary short wiring to power the unit and connect to the selected Audio channel for testing. Note that for Audio testing, the unit must be powered from the same aircraft power system as the Panel on test so the ground is common between the LHS unit and the Audio Panel. Refer to **Section 4.5.2**

If the installer suspects the actual final placement may not provide a full unobstructed view of the ground below, installers can test the unit placement location before any actual wiring or drilling. This can be done using a fresh 9V or external 12V battery to power the unit (without connecting the Audio wires). This powers the unit and allows Wi-Fi connection to the unit to check the reported range.

**It's recommended to use a 12V source for testing, either internally or from an external 12V power source.**

Note that Wi-Fi is only available during the first 5 minutes and is disabled if no connection is made to the unit Wi-Fi network.

The unit can be placed by tape or held by hand at the location desired.

Range reading can be seen on a phone or Tablet/PC via Wi-Fi connected to the unit. Refer to **Section 7** for Wi-Fi connection and software setup.

The reported range should be within 2” of the distance from the ground, assuming the unit is looking straight down. Note that if the unit is held at an angle, the reported distance will be higher. Measure the theoretical straight line between the Unit viewing window and the ground, and that distance should be within 2” of the reported distance on the Wi-Fi device.

## **4.5 Installation of Landing Height System Unit**

### **4.5.1 Internal attachment to Access Panel/Inspection Plate**

The LHS unit may only be installed or attached to a removable inspection plate. **Installers must contact the appropriate FAA office for approval if not installing the LHS on an inspection plate or access panel.**

Cut the access panel plate according to the following profile.

The unit can be oriented internally in any direction.

Two suggested methods to prepare the access panel to ensure viewing window clearance.

**Option A) Rectangle Cut-out**

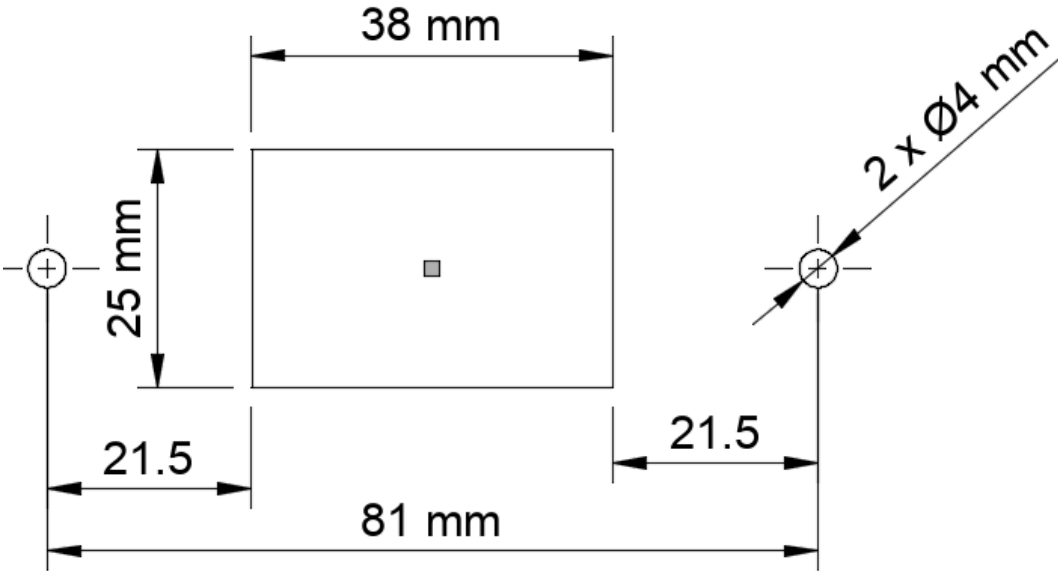

**Note:** +/- 2 mm accuracy for the rectangle cutout is acceptable as this still clears the viewing window of the Landing Height System unit.

**Option B) Using a 25 mm ( or 1”) drill bit**

Alternatively, two 25 mm holes with 14 mm apart can also clear the viewing window of the Laser module.

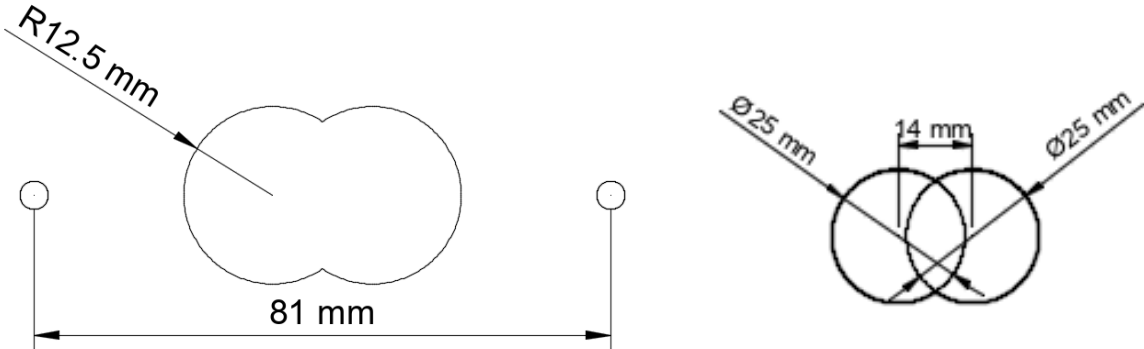



**Example of installation on a Piper Warrior with a replacement access panel**

**Example of installation on a Cirrus with the cut-out using the original access panel.**



## 4.5.2 Wiring

### Model: LHS-200-B

There are two types of quick-disconnect connector for this model, a 4-wire quick-disconnect and a 5-wire quick-disconnect. Use the appropriate table for connection.

#### Units with 4-wire quick-disconnect

RED	Aircraft Power (+12V/+24V)
YELLOW	Aircraft GND
BLUE	Audio Hi (Single-ended audio output)
GREEN	RS-232 RX (GPS Receive Input)

#### Units with 5-wire quick-disconnect

RED	Aircraft Power (+12V/+24V)
BLACK	Aircraft GND
BLUE	Audio Hi (Single-ended audio output)
GREEN	RS-232 RX (Receive Input)
YELLOW	Do Not Connect

Wires: Use 24 AWG or better aviation aircraft shielded wiring.  
All shields must be connected to ground at one end only.

Suggested wires:

For power; use 2-core shielded wires.

For Audio; use 1-core shielded wire.

For RS232: use 1-core shielded wire.

The unit uses less than 150mA of power. A dedicated 1A circuit breaker with Push/Pull feature must be used if this will be the only means to switch off the unit or disable audio. Refer to **section 4.3** for more details about the power connections and disabling the unit or audio on-demand.

## **Model: LHS-200-C**

The unit is supplied with a **5-wire quick-disconnect** connector. This allows the unit to be fully removed along with the access panel to provide access for other maintenance requirements.

<b>RED</b>	Aircraft Power (+12V/+24V)
<b>BLACK</b>	Aircraft GND
<b>BLUE</b>	Audio Hi (Single-ended audio output)
<b>GREEN</b>	RS-232 RX (Receive Input)
<b>YELLOW</b>	Gear Switch Detection input

**[\(Refer to Supplemental LHS Wiring Notes at our download page online\)](#)**

Wires: Use 24 AWG or better aviation aircraft shielded wiring.

All shields must be connected to ground at one end only.

Suggested wires:

For power; use 2-core shielded wires.

For Audio; use 2-core or 1-core shielded wire.

For RS232 & Gear Switch: use 2-core shielded wire.

The unit uses less than 150mA of power. A dedicated 1A circuit breaker with Push/Pull feature must be used if this will be the only means to switch off the unit or disable audio. Refer to **section 4.3** for more details about the power connections and disabling the unit or audio on-demand.

### **RS-232 RX (Receive Input) (Both Models)**

**(Refer to Supplemental LHS Wiring Notes at our download page online)**

**See end of this document for GPS Limitations**

The LHS 200 series can optionally connect to a GPS receiver using RS232 aviation standards. Connection to an external GPS source is not-required for standard operation of the LHS, similar to the 100 series. If connected, enable this option in the WiFi Setup. Once enabled and connected; the unit acquires various GPS data to enhance operation and offer higher GPS altitude announcements. Note that only 200 ft and below are actual AGL Laser based announcements.

Installation under the NORSEE policy requires separation from primary systems that may affect the safe continuation of the flight in the event of units malfunctioning. Care should be taken when selecting the GPS RS232 source output so it does not affect the safe operation and landing of the aircraft and its connection still meets the separation requirements of the NORSEE policy. Questions about this should be directed to your local FSDO

### **Gear Switch Up Position (LHS-200-C Model only)**

**(Refer to Supplemental LHS Wiring Notes at our download page online)**

The LHS-200-C unit can physically detect if a voltage is present on the Gear Switch Up or Down position using a fully isolated optical internal sensor.

Wire Pin 5 to the Gear Switch or single indicator light. Connection to the Gear Up position is not-required for standard operation of the LHS, similar to the 100 series. If connected, enable this option in the WiFi Setup. Once enabled and connected; the unit will announce if it detects the Gear is still in the up position when it starts to detect the ground below (200 ft or below). Refer to section “**8.8 Gear Warning System**”

### **4.5.3 Audio Interface**

**[\(Refer to Supplemental LHS Wiring Notes at our download page online\)](#)**

The unit delivers < 1W of Audio output power for connecting to an Aircraft Audio Panel or Intercom.

Select an unused Audio Channel on the Audio Panel, such as NAV2, ADF, COM3 and so on. It is recommended that the selected channel be of the “Switched” type. Meaning, the pilot can enable/disable or mix this audio input channel using a button/switch on the Audio panel; similar to when the pilot activates the NAV button/switch to identify a NAV station. This also applies to Audio Panels integrated within a Glass Panel and/or Digital type Audio panels; the pilot must be able to disable the Audio Input using the Glass Panel.

If a suitable “switched” channel is not available; then a dedicated Push/Pull 1A circuit breaker must be used to allow the pilot to disable/enable the system on-demand. Alternatively, an external toggle switch can be installed, so the pilot is able to switch off the system if desired.

#### 4.5.4 Software Setup

While the airplane is on flat ground, measure the vertical height of the unit from the ground below, and use the Wi-Fi connection to set up the unit. Refer to **Section 7** for Wi-Fi setup.

Even if the unit is looking at the ground at an angle; the vertical distance is the actual vertical height of the unit above ground.

Refer **Section 8** for Wi-Fi functions.

### 5 Maintenance

The Landing Height System does not require any field maintenance. The unit should not be installed in the engine exhaust soot stream, otherwise periodic inspection of the unit viewing window is required to clean any deposits. Use a dry, clean cloth without applying any pressure on the viewing window. A slightly wet (water only) cloth can be used if needed. Note the viewing window is black

### 6 Operating Limitations

- Pilots must be able to switch off the unit (or audio output) on demand
- The Landing Height system is not a required system and may not be used as a substitution for any certificated aircraft system.
- The system is not authorized to be used below Weather Minimums for the type of flights.

- The Landing Height System is a non-required system. It can only be used as an aid once the runway is fully identified and all regulatory requirements for landing are met without the system aid.
- The Landing Height System is not approved for use over water or if the runway has a water level of 4” or more.
- The Landing Height System is not approved for installation on float or amphibious aircraft

## 7 Wi-Fi Connection

The Landing Height System uses a Wi-Fi connection for initial setup and Audio testing. Use your device Wi-Fi Search and look for **EI\_xxxxxx**. The xxxxxx is the unique serial number of the unit.

The default Wi-Fi Password: **61331970**

The Wi-Fi System interface is designed for the Phone screen, but can be used with PCs/Laptops and Tablets such as iPads. Once connected, use your device Browser (Safari / Chrome / others) to connect to the system. Input **http://192.168.10.1** on the browser. **Some browsers may accept 192.168.10.1 directly and others may needs http://**

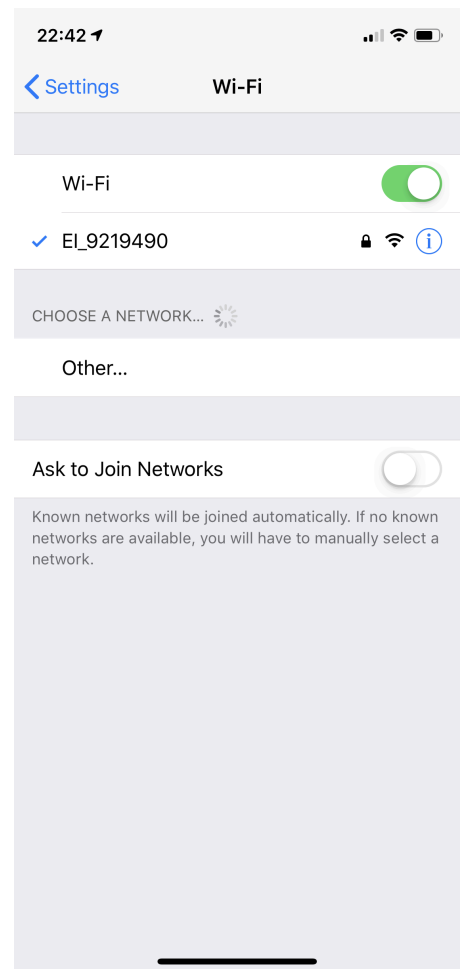

**Note, the Wi-Fi Interface is only available for the first 5 minutes after power up to allow for device connection.**

The unit detects when the main page is being displayed by a connected device and delays shutting Wi-Fi off till no activity is detected.

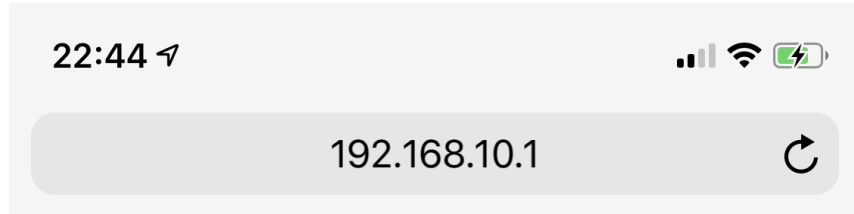

## 8 Wi-Fi Menu

### 8.1 Main Page

Once connected, the main page shows the system reported range. This is automatically refreshed and updated every 0.5 second. **No need to refresh this page manually.** The large number shows range in feet (truncated). The smaller number shows range in inches.

**Installed Height value must be set before the first flight.** Use the Set Vertical Height button to set up the unit above ground installation height when on a flat surface, engine off.

The unit uses its own range reading and the user's input value to calculate its actual install height and angle. When out-of-range or no surface detected, range reports 0.00.

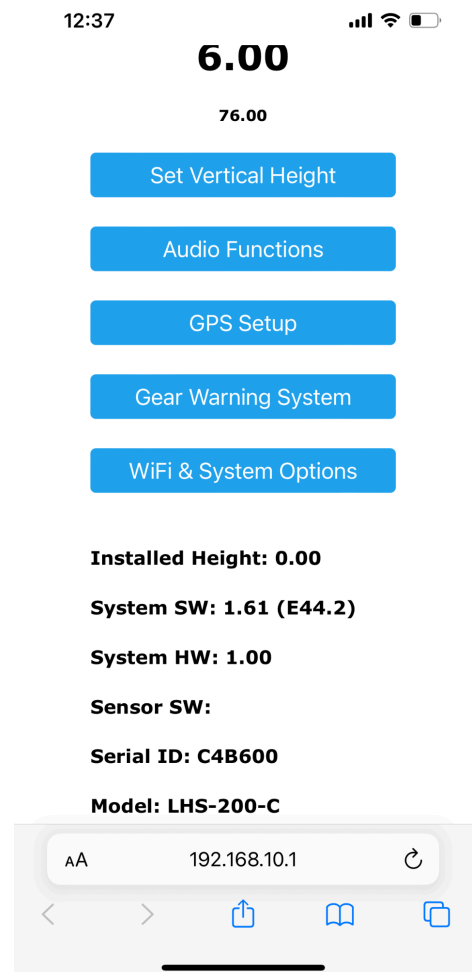

## 8.2 Installed Height Page

Use this page to input the Installed Height.

This is the actual vertical height above ground measured using a tape measure from the grounds below to the black lens at the bottom of the unit.

This value must be set for correct operation of the system. Once set; the reported range will be 0.00, indicating the distance of the wheels above the ground.

**Note: Do not set the height inside a hangar. It's best to take the airplane out to the ramp or taxiway first.**

If the displayed range is within 2" of the measured height, you can use the reported range. The Landing Height System can be installed at an angle if required. The system uses the reported range along with the user provided install height above ground to calculate and save this angle.

**Note: Setting up the initial height or Reset must be performed on the ground, on a flat surface and with the engine off.**

11:42



### Set Installed Height

**In INCHES. 0-9 & '.' allowed.  
Value between 10.00" and 90.00".  
Example: 25.44 or 24.00 or 45**

**Height: 0 is allowed and this removes  
the Saved Height Value (Reset)**

Save installed height

[Back](#)

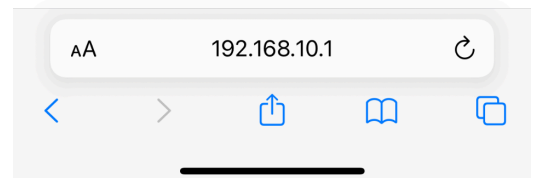

### 8.3 Audio Page

Use this page to test the Audio.

Test Audio button cycles all stored announcements. Volume and Gain can be adjusted from this page. **It is recommended to use the aircraft Audio Panel volume control if available to change the volume if desired.**

The Audio Options button allows setting up voice reminders or options. Example: “Check Landing Gear” announcement (for 200-C models only) if the Gear Warning System is not enabled.

Refer to Section “8.7 Audio Options” for more information.

11:42



#### Audio Functions

Test Audio

Audio Gain & Volume

Audio Options

[Back](#)

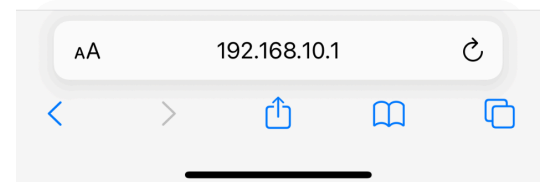

The “**Check Landing Gear**” should not be considered a primary reminder to lower the retractable landing gear. Users must be aware that this voice message may not be triggered or heard at all, even when enabled. This is designed as an extra or added non-primary aid.

## 8.4 Wi-Fi Page

This page allows changing the default Wi-Fi network name with any other name, such as your Tail-Number. When changed, the system will restart, search and connect to the new Wi-Fi network name. Note, this is case-sensitive.

### **It's recommended to change the default Wi-Fi Password**

**When changing the password, make sure at least one of your devices (phone or iPad) saves the new password and can connect to the unit again without asking for the password. If you forget the new password, the only way to reset it is either by using a device (phone or iPad) that saved the password and reset using this page or by returning the unit back for firmware re-programming.**

**We have no way of knowing your new password if you are unable to connect to the unit.**

## 8.5 System Page

Firmware upgrades and Audio changes (such as a different language for callouts) can be requested or downloaded as they become available on our site.

## 8.6 GPS Setup

**This feature is for situational awareness only.**

**Do not use for navigation or approaches.**

This feature allows receiving GPS data using RS232 in Aviation Output format. Aviation Output Format, sometimes also called MAPCOM, commonly uses 9600 baud.

It offers announcements for GPS reported altitude at 3000 ft, 2000 ft, 1000 ft and 500 ft. It also detects GPS reported airplane speed.

Note that most GPS units report altitude in MSL and some even provide the altitude to the nearest 100 ft. Some GPS units report Altitude based on their internal Terrain Map and offer “Above Terrain” height. Additionally, some do not report Altitude at all, even with Aviation Output. **KNOW YOUR GPS.**

Once enabled; go back to the same GPS page, the unit reports if it is receiving the correct data by showing Alt: & Speed: data. If the GPS output format selected is not compatible with the LHS; “Waiting for Data...” is shown. GPS source needs to be on and acquired a GPS fix.

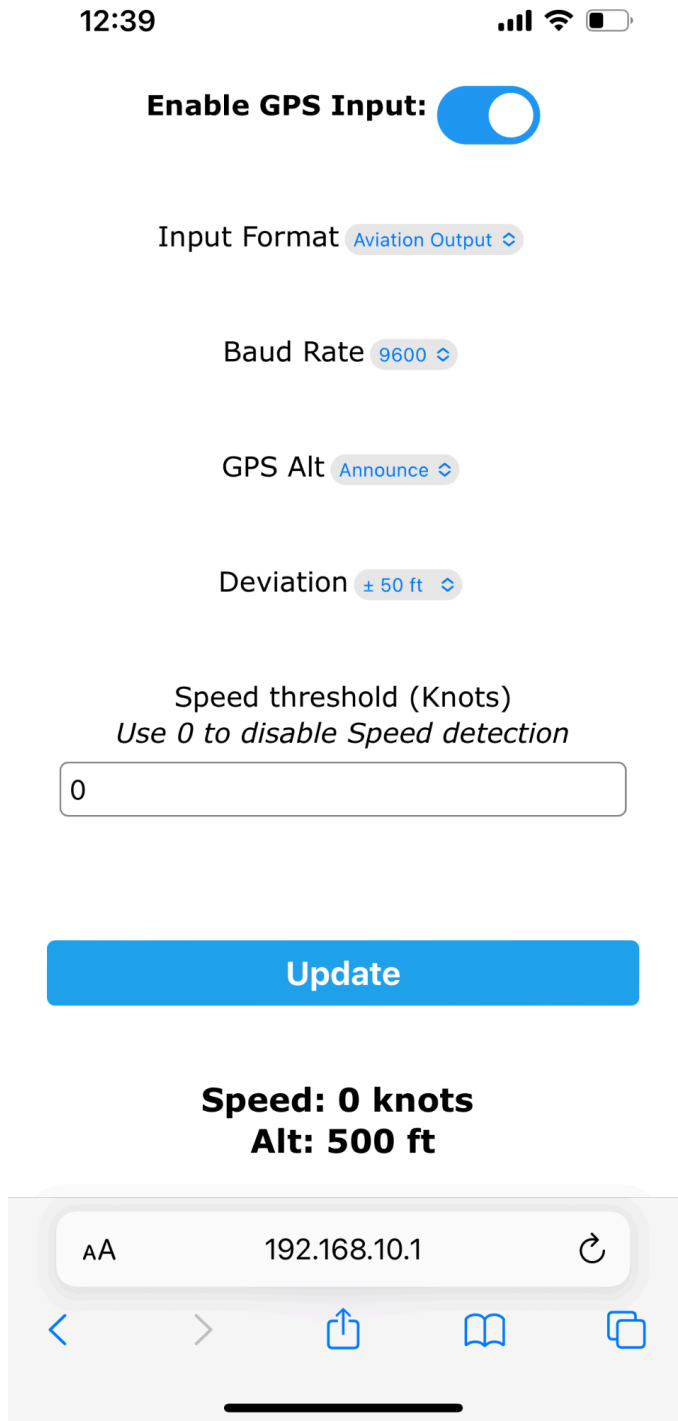

The altitude will be reported once. Either reaching this altitude, climbing or descending. The “Deviation” option allows for the reported GPS Altitude to deviate within the selected margin (+ or -) without announcing that altitude again. Depending on if the GPS is reporting altitude to the nearest 100 ft or nearest 10 ft, if the LHS unit is repeating the announcement, it means the GPS reported another value away from the Deviation margin selected.

For the Speed option; the LHS disables announcements when reported speed is higher than selected. To use this feature; input a value that is higher than your approach speed. Input 0 to disable this feature. This feature is only intended for some customers that fly high and into IMC.

The 200-X models introduced an additional software layer to detect ice crystals and other laser hits while flying IMC. Pilots can try to fly IMC before enabling this option to check if any hits or announcements escape the new software routine.

Keep in mind that the GPS reported speed is in Ground Speed. For example; If an airplane approaches speed is 60 knots, and cruises at 120 knots, while flying into a 30 knot headwind, the GPS reported speed is expected to be 90 knots. Using 80 knots as the Speed value provides a good margin between approach speed and ground speed.

If GPS Input is enabled but no GPS data being received (GPS off or not set up for Aviation Output), these settings are ignored

## 8.7 Audio Options

LHS firmware v1.6 or higher, includes both Female & Male voices for the announcements.

On 200-C models; Gear Reminder to announce “Check Landing Gear” a single time is available if the Gear Warning System is not enabled. If the Gear Warning System is enabled, this reminder option is not available.

Power-On Announcements, once enabled, announces “Landing Height System Ready” after the desired set time. This option confirms the Audio channel is enabled and working correctly and can be used to troubleshoot if the unit power is intermittent, as if this is the case, the unit will restart during flight and the announcement will be heard again.

12:38



### Audio Options

---

**Gear Reminder:**

**Use Female Voice:**

---

### Power On Announcement

If enabled, the LHS announces a message after power on.

Select the time delay for this announcement, depending on when you normally put on the headset after airplane Master On.

### Option & time-delay active on next Power On

**Power On Announcement:**

Announcement 10 minutes after Power On

192.168.10.1

---

## 8.8 Gear Warning System

The LHS 200-C unit is able to detect the configuration or status of the landing gear using three different methods. A single wire is used for all these methods.

LHS 200-C Gear Detection feature is disabled by default and can be enabled using WiFi setup. The method of detection is also selected when enabling this feature.

Once enabled, go back to the same setup page and check the status of the wire.

Method 1: Detect Gear Switch Up

Method 2: Detect Gear Switch Down

Method 3: Detect Ground Reference

**[\(Refer to Supplemental LHS Wiring Notes at our download page online for Methods explanation\)](#)**

12:38



### Gear Warning System

Gear Warning System:

Method Detect Gear Switch Down Position

Update

### Gear Down

[Back](#)

